

IDAN PIPE HOBBY CATALOGUE



Dear pipe friends and hobby pipemakers,

we are pleased to have arisen your interest in our Hobby catalogue. Before you begin to leaf through our assortment, please read the following remarks and hints.

This special catalogue follows a different concept than our main catalogues with their annually appearing renewed editions. Our Hobby Catalogue offers a permanent basic assortment of items for hobby pipemaking. The briar blocks, mouthpieces and additional items presented here are, for the most part, specially made to our demands. But the „world of pipes and tobacco“ has changed a lot over the past years, and getting sufficient supplies has turned out to be more and more difficult. The number of pipe producers and their suppliers has gone down to only a fraction and, as a result potential suppliers for the items our hobby assortment have become rare. For this reason we must ask for your understanding should delivery problems or changes in our hobby assortment occur without notice.

We always try to keep prices stable, but corrections become inevitable from time to time. For this reason we bring out a separate price list for our Hobby Catalogue. With its appearance every autumn together with our main catalogues, prices of the previous list become invalid. To be sure to have the correct version at hand for your orders, please ask for the new hobby price list from middle of October.

Some people tend to learn best when they see what is and has to be done. All those who want to try pipemaking for the first time should make up their mind whether to order our 45 minute video film which demonstrates all steps of making your own pipe - even though the words only come in German. The video is accompanied by our instructions leaflet with explaining text translated into English language, so it should still be possible to follow the film action.

We wish you a lot of fun and success with your hobby and remain

yours DAN PIPE

(H. Frickert)

6th edition, English translation 10/2011
Text, translation and sketches: Holger Frickert
All rights reserved to DAN PIPE - Lauenburg

Technical changes may be subject to changes without notice.

DAN PIPE

Dr. Behrens KG

Hafenstrasse 30 - D-21481 Lauenburg

Tel.: ++ 49 41 53 / 59 89 - 0 - Fax: ++ 49 41 53 / 59 89 69

e-mail adress: pipe@danpipe.de - online shop: www.danpipe.de

www.pipetobacco.de

Briarwood (*Erica arborea*), the basic material in pipe production, is related to our native heather plant. The briar grows wild in many of the alpine rock and karst landscapes in most countries all around the Mediterranean Sea and is part of the more or less lush underwood vegetation known as „Macchia“. Depending on the weather's and the soil's conditions, the briar bushes reach a height of 2 to 3 meters or even more. Some (not all!) briar plants grow bulbous tubers in the section between their stem and their roots that dig deeply into soil and crevices. Depending on growth conditions and age, these tubers can reach the size of a football or even a medicine ball. These tubers are dug out, which is a really tough job in most cases, and cut into blocks on a large circular saw by the „coupeurs“. We roughly divide the types of briar blocks in two variations, „**plateau blocks**“ and „**standard blocks**“. The most sought-after plateau wood originates from the outer parts of the briar tubers and comes with the nature-grown rough bark, whereas the standard blocks are more or less cut from the inner parts. The coupeur's eye and experience determine how many and what type of blocks can be cut from one tuber. When the briar is cut aiming for plateau quality, the amount of rejects is much higher than when the cutting goes for standard blocks. Thus, prices of plateau wood are generally higher than those of standard wood.

The accompanying sketch shows a section of a briar burl. The dotted lines marking numbered areas are only meant as an aid to orientation, transitions are fluid. Some tubers only bring out two or three blocks.

- 1 plateau area with the nature-grown bark
- 2 standard block area
- 3 stem area, due to poor grain and fairly heavy weight only used for cheap mass production
- 4 root area, heavily fissured and infiltrated with dirt and sand, not used for pipe production

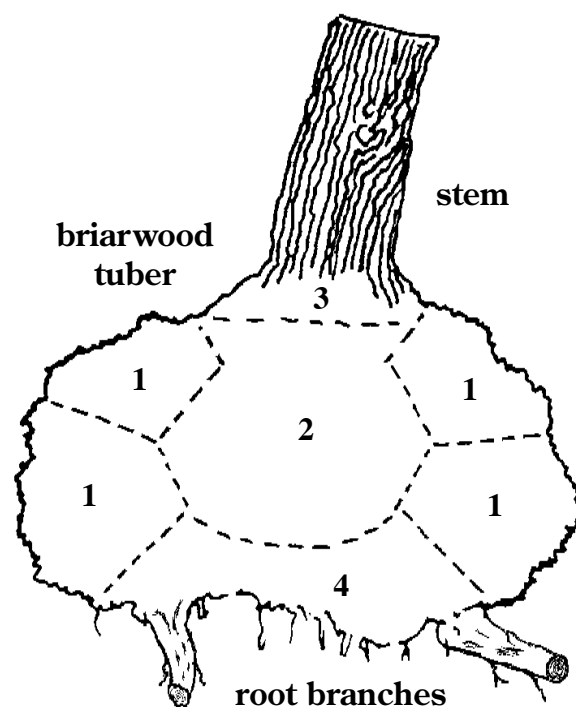

And now some remarks about the blocks presented on the following pages.

Briarwood is a **natural grown material** and its composition and quality is subject to fluctuation. Like roots it grows completely or partly underground and can therefore always bear small inclusions of sand or earth, remainders of carbon from bush fires, small cavities or cracks. As long as **flaws** are visible from the outside, the affected blocks are sorted out. Should you still find flaws on a block that we failed to see, please return the block to us for replacement **before** having started to work it. We cannot accept responsibility for flaws that only come to light in the course of your carving work. This is a risk that also professional pipemakers have to take with their work. For that reason, **briar blocks that have already been worked are excluded from replacement.**

On the following pages we offer you both raw untreated blocks and various pre-drilled blocks with the holes drilled to various bend angles and a mouthpiece fit. Both variations are available as plateau blocks or standard blocks. Should you want to create shapes that our pre-made blocks are not suitable for, you can send us a sketch or choose a pipe from our main catalogue assortment, our workshop staff will gladly find and drill a raw block of size (plateau only) for you and fit a mouthpiece.

Plateau blocks are cut from the outer parts of the briar tuber. The natural-grown rough bark is left untouched, because many pipemakers highly estimate its characteristically structured relief as a special style component on their pipe creations. In plateau blocks, the grain generally runs in more or less close lines from the bark down towards the former middle and bottom of the briar tuber. According to the tuber's more or less ball-shaped stature, the lines tend to spread out like a fan. This type of pattern is called „flame grain“ or, with really close and even lines, „straight grain“.

Pre-made plateau blocks are available with two different drilling angles and the stern of the future stem smoothed out: **80°** for the making of half-bent pipes and **60°** for the making of bent pipes. They are mounted with an ebonite mouthpiece, and you can choose between a **9mm filter** or a **non-filter** version. The fanned grain makes plateau blocks only rarely suitable for classic pipes with a 90° angle of bowl and stem (e. g. Billiard), we have confined our offer to only the 60° and 80° drilling angles. Due to a decreasing demand, plateau blocks with the mouthpiece piercing through the natural bark (as found on Danish „Freehand“ or „Fancy“ pipes) have been taken from our basic assortment. Still, we can specially prepare this type of block for you if requested, as we can blocks with 90° drilling angle.

Some words about drilling

All those in possession of a well-equipped hobby workshop and some experience in wood-crafting (maybe also in pipemaking) will, of course, want a maximum of freedom in shaping his pipes and therefor prefer raw briar blocks which can be drilled or turned as required for the shapes planned.

For an optimal fusion of grain patterns and the pipe's shape, a plateau block can be drilled in different ways. To make a pipe with a cup-shaped bowl one should always drill the tobacco hole from the bark side (Fig.1), whereas drilling from the bottom side suits best for tulip-shaped bowls (Fig.2). The sketches below show the grain patterns and pipe shapes, and they also show that plateau grain is hardly suitable for classic straight pipes, as the grain will not really harmonize with their upright bowl.

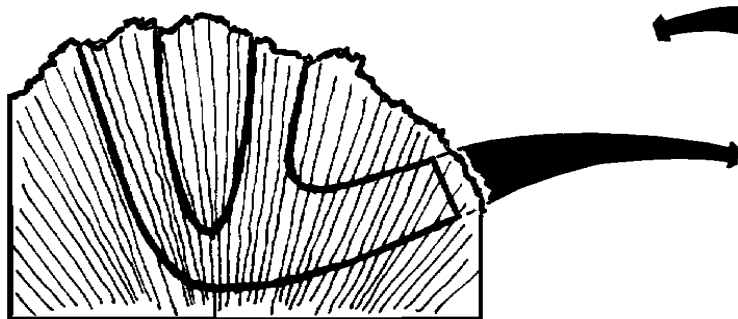

Fig. 1 : cup-shaped bowl
plateau block drilled from the bark side

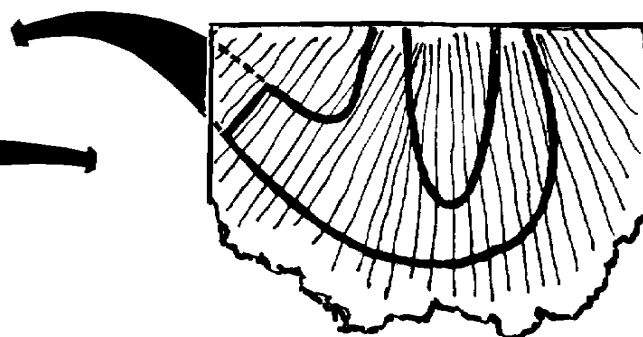
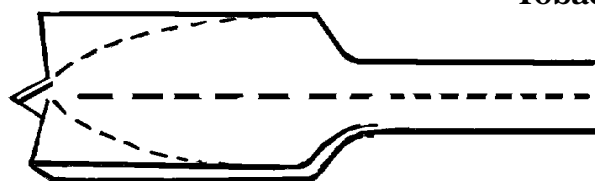

Fig. 2 : tulip-shaped bowl
plateau block drilled from the bottom side

Both **smokehole** and **peghole** can be drilled perfectly with customary spiral drills (extra long drills of 3,5mm diameter for the smokehole will probably have to be specially ordered in a hardware store). In a pipe factory, the **tobacco hole** is normally turned out to diameters of 19 to 21 mm on a lathe or a similar machine using a single steel carving blade. For hobby purpose, re-grinding a spiral drill of appropriate size into the required slightly conic shape with rounded tip did not prove. A sharp cutting edge can hardly be achieved, and the frictional heat in drilling easily burns the wood and will blunt the tool very soon. Instead, we suggest that you prepare your own spade-shaped tobacco hole drill (or have it made by a fitter) using a classic flat wood drill with centre tip (see sketch page 5) as used by carpenters. It should be appr. 21 mm wide and slightly tapered towards the rounded tip. Take care to have it made exactly symmetric to prevent the drill from rumbling and creating uneven holes. Drilling should best be done at low speed to let the drill steadily and smoothly carve into the wood.

Tobacco hole drill



wood drill, original shape...

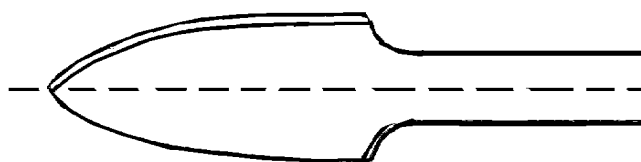

...re-ground to spade shape

Raw briar blocks

Standard block, raw (size similar to 90° /60° blocks of page 6) Best.Nr. 1360-1

Plateau blocks, raw

small: size slightly smaller than sketches on page 7 Best.Nr. 1350-1

medium: size similar to sketches on page 7 Best.Nr. 1350-2

large: size larger than sketches on page 7 Best.Nr. 1350-3

Plateau blocks are never cut to exactly the same size, the composition of sizes in one bale of 24 dozen blocks can vary from one delivery to the next and is outside of our influence.

Extra large plateau blocks are not constantly available, please ask about current availability.

Standard blocks are cut from all parts of the briar tuber, mostly from the inner areas. Their grain pattern is mixed, and they show both areas with „flame grain“ or „straight grain“ and also areas with „bird’s eye“ grain (which is a cross-section of the straight grain). This type of block calibre is mostly used in factory pipe production (then once more subdivided and traded in many special size and shape categories). Because of their predominant „cross grain“ or „bird’s eye“ grain patterns they are best suitable for the production of classic pipe shapes but, if carved consideredly and skillfully with optimal integration of the different grains they can also be turned into really beautiful artistic pipe sculptures. We offer standard blocks both as raw blocks (see above) of medium size and as pre-drilled blocks with three different drilling angles, the stem pre-turned and mounted with an ebonite mouthpiece.

Our raw standard blocks are appr. the same size as the sketches of the pre-drilled blocks on page 6. The sketches below show the traditional ways of drilling these blocks for either straight or bent pipes. When drilling from the bottom for a bent pipe, we recommend to cut off the upper edge (dotted line) before you drill the smokehole and the peghole. For a smooth right-angled stern of the future stem you can use a special drill normally used for sinking-in closet hinges. This is best done before you drill the peghole, with the block then remaining fixed in the same position.

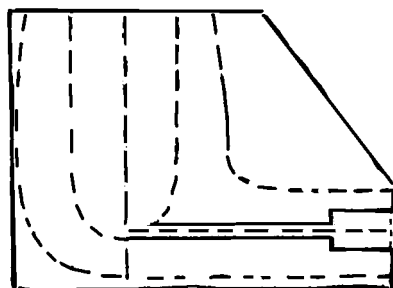

drilled from the top for straight pipes

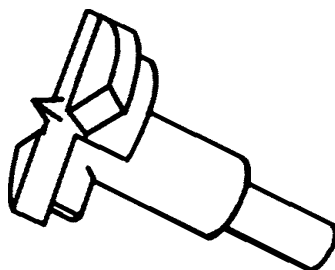

special drill for sunk-in closet hinges

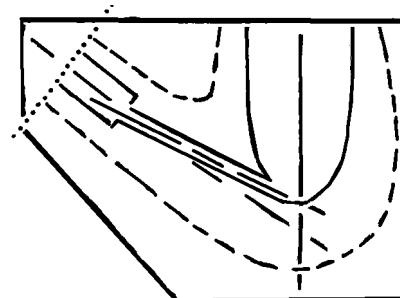

drilled from the bottom for bent pipes

Pre-made standard blocks are available in the **9mm filter** or in the **non-filter** version, both types come with three different drilling angles: **30°** for the making of full-bent pipes, **60°** for the making of medium bent pipes and finally **90°** for the making of classic straight pipes (see next page).

Standard blocks, pre-drilled, stem pre-turned, with ebonite mouthpiece

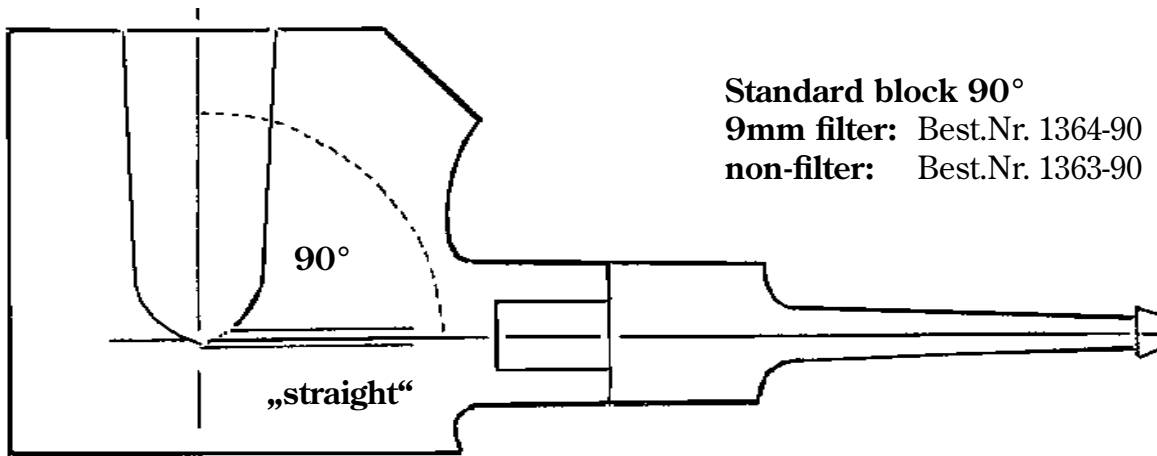

Standard block 90°
9mm filter: Best.Nr. 1364-90
non-filter: Best.Nr. 1363-90

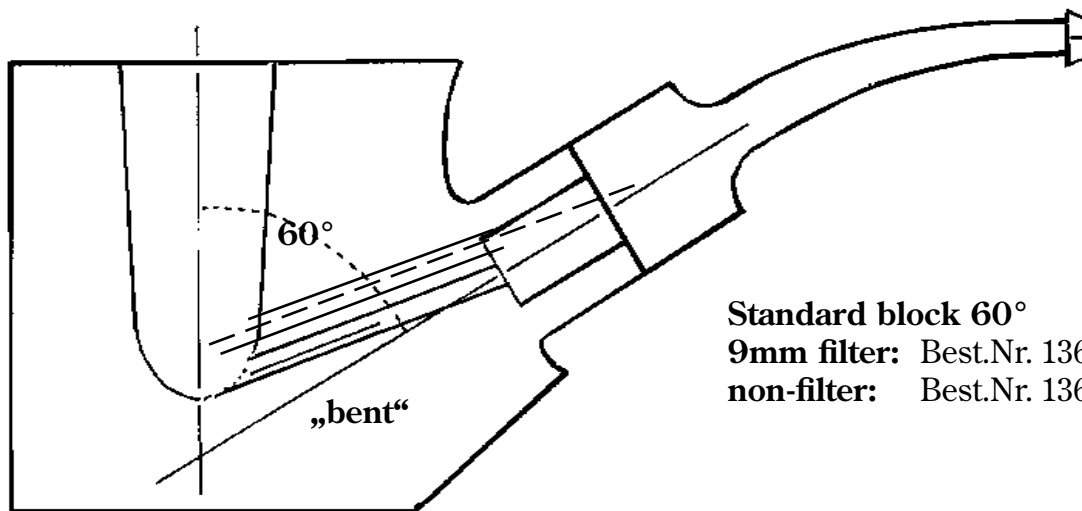

Standard block 60°
9mm filter: Best.Nr. 1364-60
non-filter: Best.Nr. 1363-60

Sketches appr. original size,
block width appr. 40 - 45 mm .
Divergence in block size and
mouthpiece shape may occur.

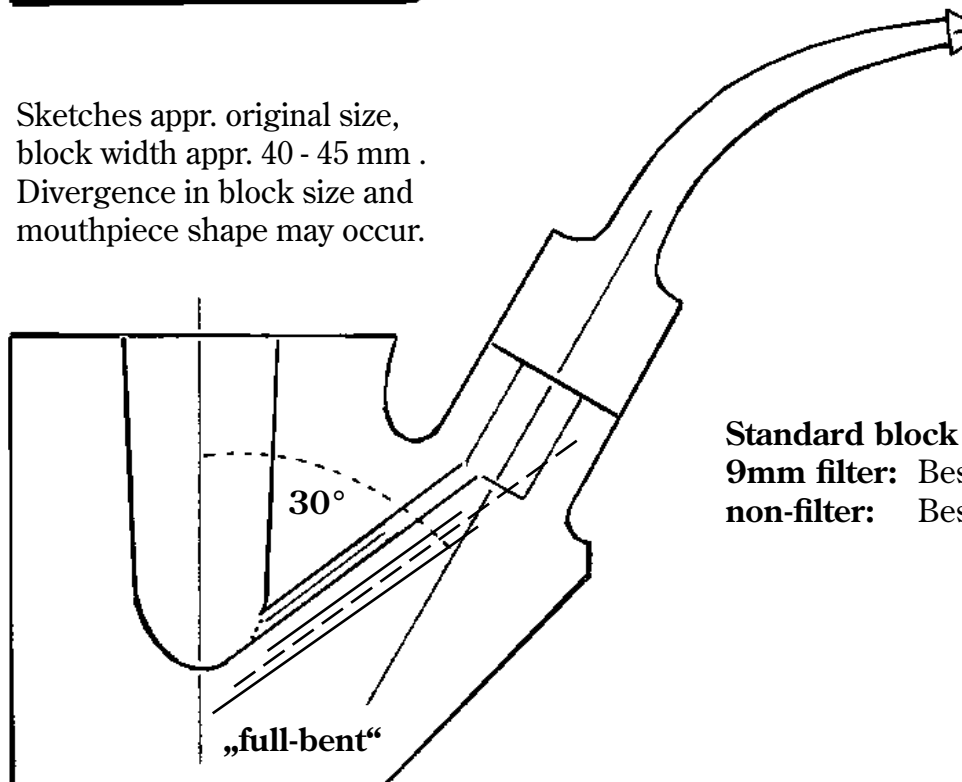

Standard block 30°
9mm filter: Best.Nr. 1364-30
non-filter: Best.Nr. 1363-30

Plateau blocks, pre-drilled, stem face turned, with ebonite mouthpiece

These blocks are available in three sizes:

„small“, slightly smaller than shown in the sketches, „medium“, as shown on this page, and „large“, larger than shown in the sketches (e.g. higher and/or longer).

Sketches appr. original size, block width appr. 40 - 50 mm. Plateau blocks are inevitably subject to size divergence also within each single category (see page 6) as they are not cut to exact measures.

Plateau block 60° „medium“

9mm filter: Best.Nr. 1352-62

non-filter: Best.Nr. 1351-62

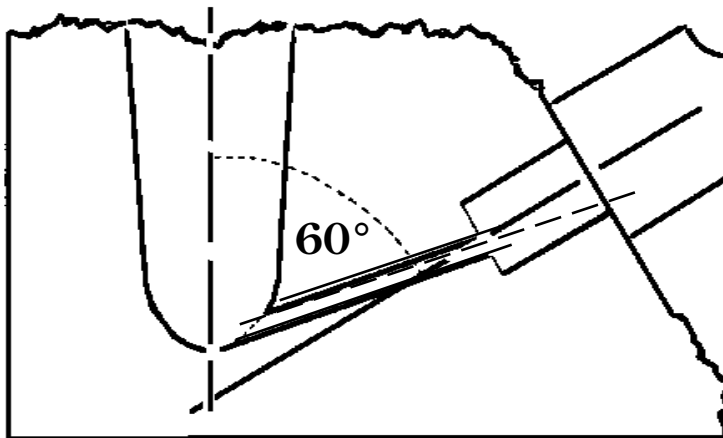

Plateau block 60° „small“

9mm filter: Best.Nr. 1352-61

non-filter: Best.Nr. 1351-61

Plateau block 60° „large“

9mm Filter: Best.Nr. 1352-63

non-filter: Best.Nr. 1351-63

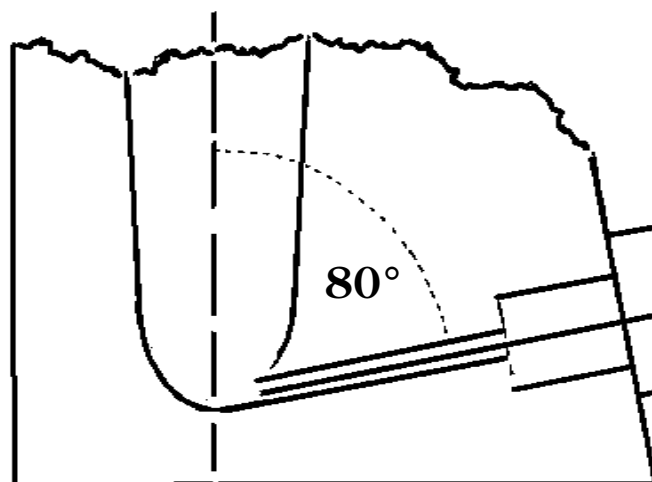

Plateau block 80° „medium“

9mm filter: Best.Nr. 1352-82

non-filter: Best.Nr. 1351-82

Plateau block 80° „small“

9mm filter: Best.Nr. 1352-81

non-filter: Best.Nr. 1351-81

Plateau block 80° „large“

9mm filter: Best.Nr. 1352-83

non-filter: Best.Nr. 1351-83

Plateau blocks specially made to order

It may be difficult for you sometimes to make individual pipe shapes from these pre-drilled blocks with fixed angles. If you send an original size sketch of the pipe you want to make or name a pipe shown in our catalogue, we will gladly choose a suitable block from our stock and drill it for you as required for that particular pipe shape. We will then charge the price for a raw block (by size) and additionally charge the work for drilling and fitting a mouthpiece of your choice from our assortment. For further information please inquire by fax, e-mail or phone.

Mouthpieces

The following pages display a rich choice of **pipe mouthpieces**. Apart from the customary tapered and saddle fishtail mouthpieces of various size and length we also offer some so-called „fancy“ mouthpieces as frequently used on „freehand pipes“ in the Danish style.

Pipe production has decreased enormously in all producing countries over the past years, the number of producers in Europe has shrunk to just a dozen. The only still remaining producer of ebonite mouthpieces has cut down his assortment of shapes to the absolute necessary. So, it is getting more and more difficult to maintain a full and regular supply of the mouthpieces in our catalogue. We have to ask for your forbearance should we have to switch over to a mouthpiece with diverging measures just to be able to deliver at all.

Following the trends of pipe production we also offer a choice of **acrylic mouthpieces** apart from the traditionally approved **ebonite mouthpieces**. Some of the acrylic mouthpieces are now also available in amber-like colours „Honey“ (yellowish) and „Brandy“ (brownish). Different from the pressed ebonite blanks, acrylic mouthpieces are milled from solid material on special copying machines by lower quantities, in consequence their price is of course higher than the price of ebonite blanks.

Mainly in our repair workshop's interest, we try to maintain a greatest possible variety of mouthpiece shapes and to always have sufficient stock. Due to the fairly large quantities required for delivery by the producers we cannot always order new stock whenever needed, and we have to apologize in advance for possible delivery problems or delays.

Our sketches show the mouthpiece blanks partly seen from above (ebonite) and partly seen from the side (acrylic), the sketches also give additional information about the important measures: \emptyset = diameter (width x height on oval mouthpieces) and length of the mouthpiece, width of the bit etc. Slight divergence from these measures can occur (see above).

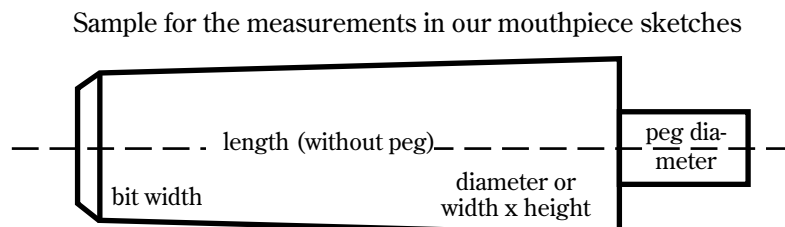

Measures always apply to the raw mouthpiece

All mouthpieces are available either as **raw blanks** or with the **peg pre-turned to fit**.
Please, read this important notice:

Mouthpieces with pre-turned peg (non-filter or with 9mm filter) can only be delivered for pre-drilled briar blocks ordered at the same time. The pegs have to be individually turned to measure for each single block to achieve a proper fit. **Pre-turned mouthpieces cannot be changed or taken back.**

Should you order more than one block plus additional pre-turned mouthpieces of different shape, **please note exactly which mouthpiece is supposed to fit which block.** Due to different density and humidity contents of every single block peg holes may be subject to divergence in diameter even though they were drilled to the same measure. In consequence, also mouthpieces do not automatically fit into each of the blocks even if the pegs were turned to equal diameter.

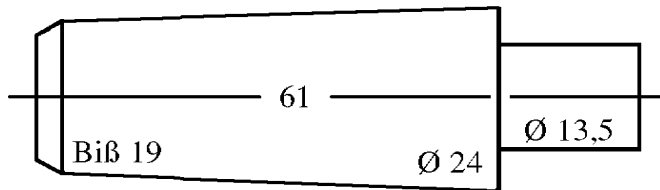

Mouthpiece Nr. 1/2

raw blank Best.Nr. 1370-1
 pre-turned, non-filter Best.Nr. 1371-1
 pre-turned, 9mm filter Best.Nr. 1372-1

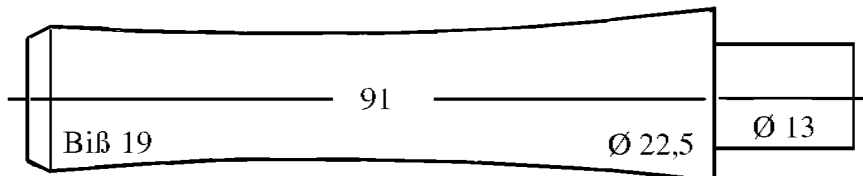

Mouthpiece Nr. 2/2

raw blank Best.Nr. 1370-2
 pre-turned, non-filter Best.Nr. 1371-2
 pre-turned, 9mm filter Best.Nr. 1372-2

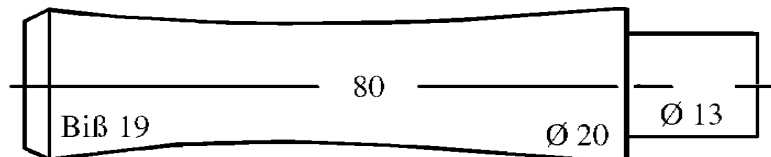

Mouthpiece Nr. 3

raw blank Best.Nr. 1370-3
 pre-turned, non-filter Best.Nr. 1371-3
 pre-turned, 9mm filter Best.Nr. 1372-3

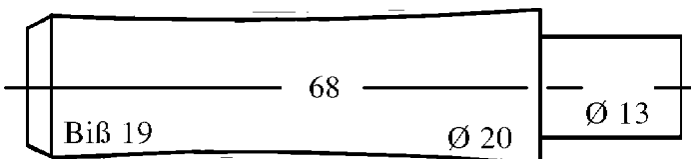

Mouthpiece Nr. 4

raw blank Best.Nr. 1370-4
 pre-turned, non-filter Best.Nr. 1371-4
 pre-turned, 9mm filter Best.Nr. 1372-4

Mouthpiece Nr. 5 is no longer available

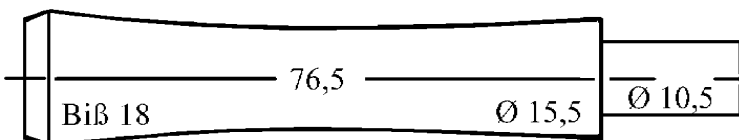

Mouthpiece Nr. 6

raw blank Best.Nr. 1370-6
 pre-turned, non-filter Best.Nr. 1371-6
 not suitable for 9mm filters

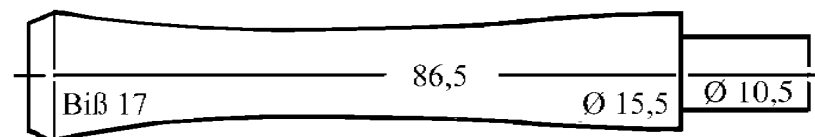

Mouthpiece Nr. 7

raw blank Best.Nr. 1370-7
 pre-turned, non-filter Best.Nr. 1371-7
 not suitable for 9mm filters

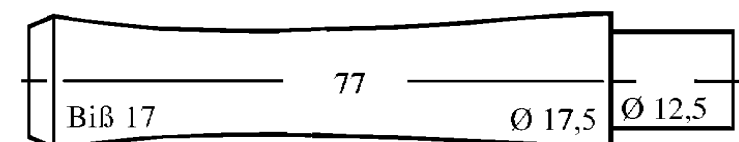

Mouthpiece Nr. 8

raw blank Best.Nr. 1370-8
 pre-turned, non-filter Best.Nr. 1371-8
 pre-turned, 9mm filter Best.Nr. 1372-8

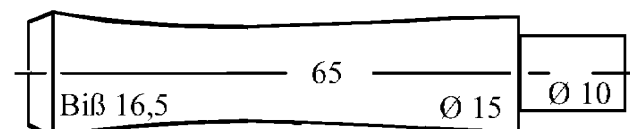

Mouthpiece Nr. 9/2

raw blank Best.Nr. 1370-9
 pre-turned, non-filter Best.Nr. 1371-9
 not suitable for 9mm filters

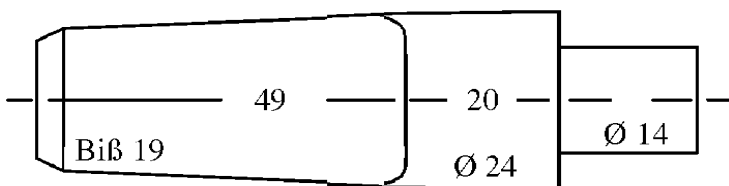

Mouthpiece Nr. 10

raw blank
pre-turned, non-filter
pre-turned, 9mm filter

Best.Nr. 1370-10
Best.Nr. 1371-10
Best.Nr. 1372-10

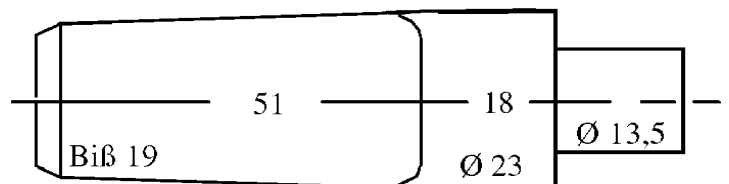

Mouthpiece Nr. 11

raw blank
pre-turned, non-filter
pre-turned, 9mm filter

Best.Nr. 1370-11
Best.Nr. 1371-11
Best.Nr. 1372-11

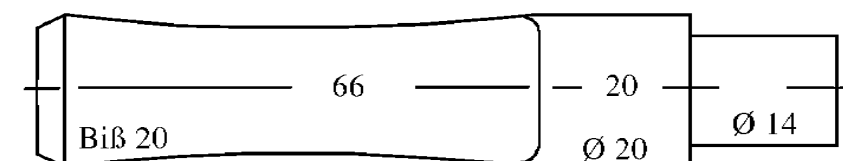

Mouthpiece Nr. 12

raw blank
pre-turned, non-filter
pre-turned, 9mm filter

Best.Nr. 1370-12
Best.Nr. 1371-12
Best.Nr. 1372-12

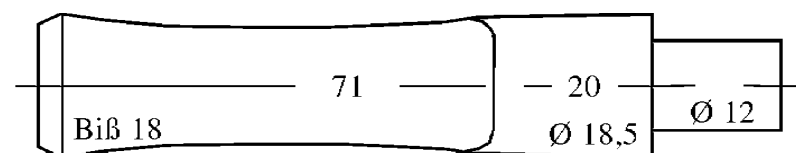

Mouthpiece Nr. 13

raw blank
pre-turned, non-filter
pre-turned, 9mm filter

Best.Nr. 1370-13
Best.Nr. 1371-13
Best.Nr. 1372-13

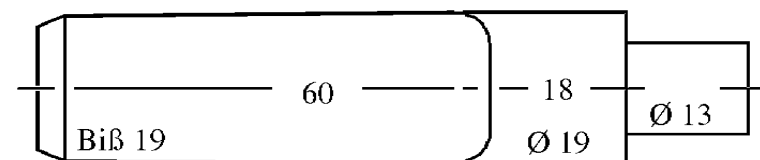

Mouthpiece Nr. 14

raw blank
pre-turned, non-filter
pre-turned, 9mm filter

Best.Nr. 1370-14
Best.Nr. 1371-14
Best.Nr. 1372-14

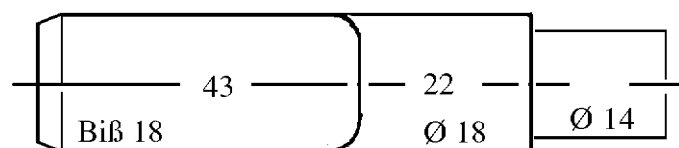

Mouthpiece Nr. 15

raw blank
pre-turned, non-filter
pre-turned, 9mm filter

Best.Nr. 1370-15
Best.Nr. 1371-15
Best.Nr. 1372-15

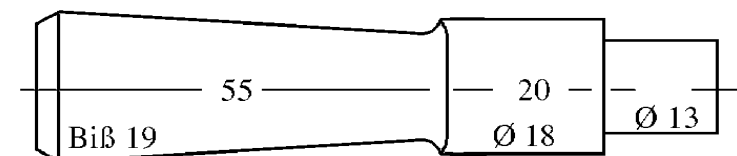

Mouthpiece Nr. 16

raw blank
pre-turned, non-filter
pre-turned, 9mm filter

Best.Nr. 1370-16
Best.Nr. 1371-16
Best.Nr. 1372-16



Mouthpiece Nr. 17

raw blank
pre-turned, non-filter
not suitable for 9mm filters

Best.Nr. 1370-17
Best.Nr. 1371-17

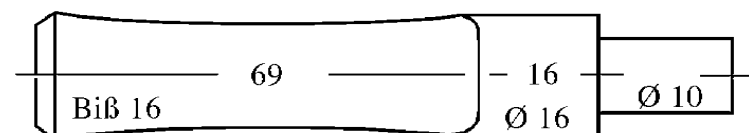

Mouthpiece Nr. 18

raw blank
pre-turned, non-filter
not suitable for 9mm filters

Best.Nr. 1370-18
Best.Nr. 1371-18

Round saddle mouthpieces

(Please take notice of our explanations on page 8!)

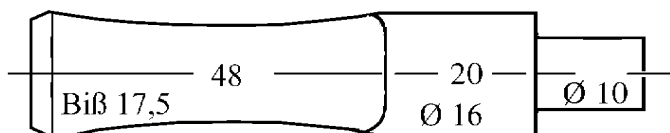

Mouthpiece Nr. 19

raw blank
pre-turned, non-filter
not suitable for 9mm filters

Best.Nr. 1370-19

Best.Nr. 1371-19

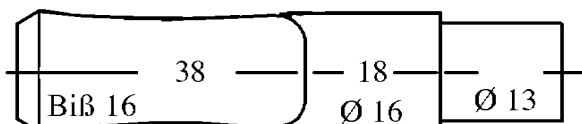

Mouthpiece Nr. 20

raw blank
pre-turned, non-filter
pre-turned, 9mm filter

Best.Nr. 1370-20

Best.Nr. 1371-20

Best.Nr. 1372-20

Oval saddle mouthpieces

(instead of diameter measure : width x height)

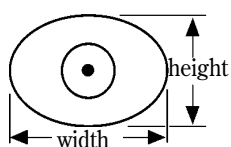

ebonite

Mouthpiece Nr. 21 is no longer available

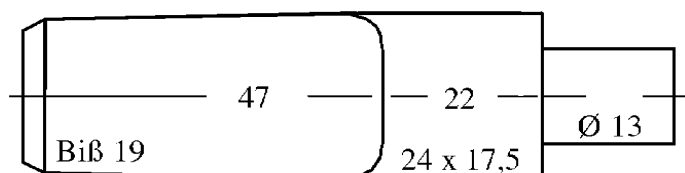

Mouthpiece Nr. 22

raw blank
pre-turned, non-filter
pre-turned, 9mm filter

Best.Nr. 1370-22

Best.Nr. 1371-22

Best.Nr. 1372-22

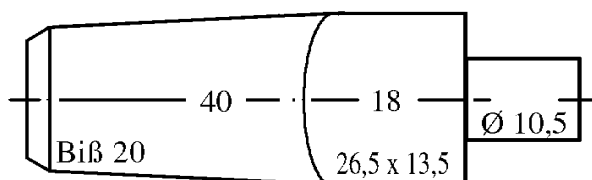

Mouthpiece Nr. 23

raw blank
pre-turned, non-filter
not suitable for 9mm filters

Best.Nr. 1370-23

Best.Nr. 1371-23

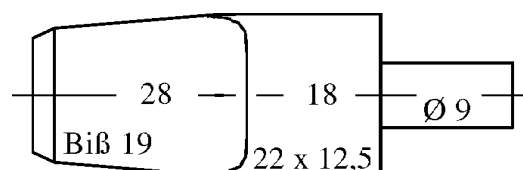

Mouthpiece Nr. 24

raw blank
pre-turned, non-filter
not suitable for 9mm filters

Best.Nr. 1370-24

Best.Nr. 1371-24

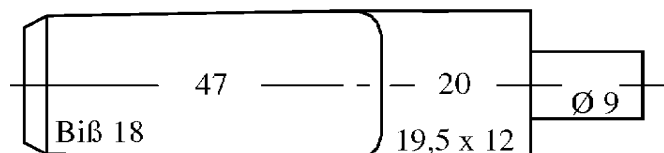

Mouthpiece Nr. 25

raw blank
pre-turned, non-filter
not suitable for 9mm filters

Best.Nr. 1370-25

Best.Nr. 1371-25

Mouthpiece Nr.26 is no longer available

Important notice about grinding and papering the ebonite mouthpieces from pages 9 - 13.

These mouthpieces are made of a special composition of raw rubber blended with ground ebonite and other ingredients that is pressed in moulds and then vulcanized, and they are lower in density than mouthpieces carved from solid rod material (see page 14). Producers guarantee a grinding depth of 1 mm for their blanks. If worked deeper, discoloured spots, small impurities or air bubbles may appear.

Oval saddle mouthpieces

(instead of diameter measure : width x height)

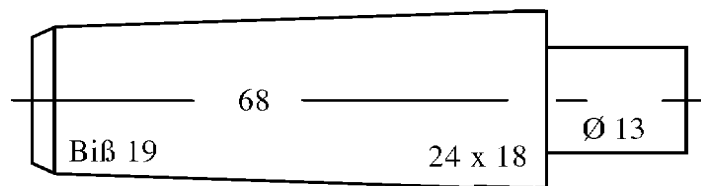

Mouthpiece Nr. 27

raw blank
pre-turned, non-filter
pre-turned, 9mm filter

Best.Nr. 1370-27
Best.Nr. 1371-27
Best.Nr. 1372-27

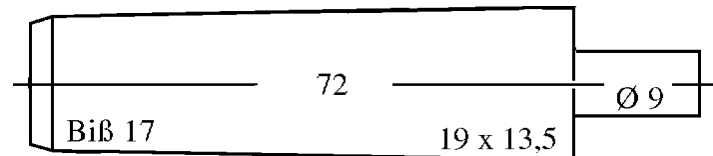
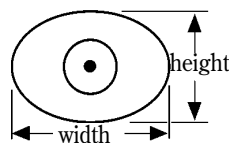

Mouthpiece Nr. 28

raw blank
pre-turned, non-filter
not suitable for 9mm filters

Best.Nr. 1370-28
Best.Nr. 1371-28

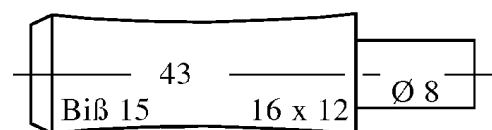

Mouthpiece Nr. 29

raw blank
vorgedreht, ohne Filter
not suitable for 9mm filters

Best.Nr. 1370-29
Best.Nr. 1371-29

(Please take notice of our explanations on page 8!)

Square-cut mouthpieces, tapered or with saddle

For these mouthpieces with „diamond-shaped“ cross-section we have noted the largest width and the width of the four faces.

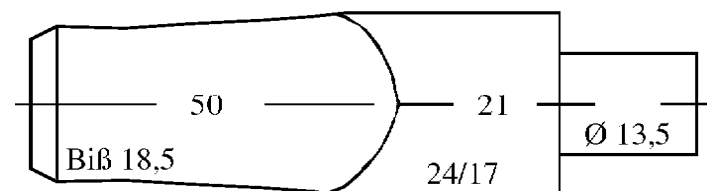
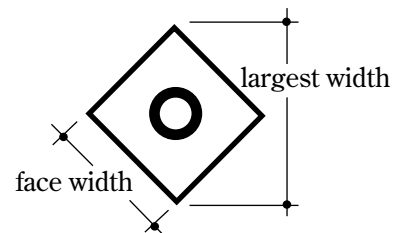

Mouthpiece Nr. 30

raw blank
pre-turned, non-filter
pre-turned, 9mm filter

Best.Nr. 1370-30
Best.Nr. 1371-30
Best.Nr. 1372-30

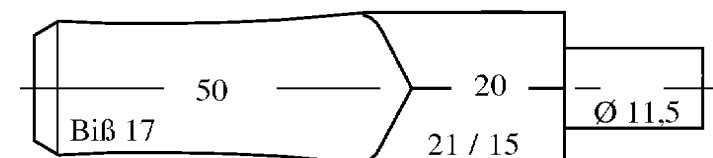

Mouthpiece Nr. 31

raw blank
pre-turned, non-filter
not suitable for 9mm filters

Best.Nr. 1370-31
Best.Nr. 1371-31

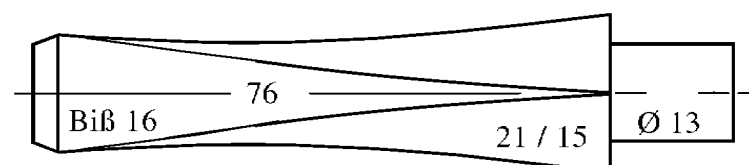

Mouthpiece Nr. 32

raw blank
pre-turned, non-filter
not suitable for 9mm filters

Best.Nr. 1370-32
Best.Nr. 1371-32

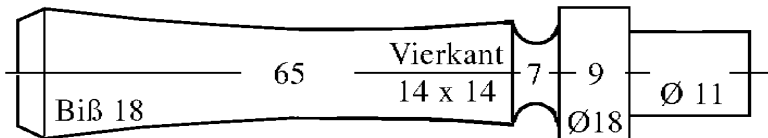

Mouthpiece Nr. 33

raw blank Best.Nr. 1370-33
 pre-turned, non-filter Best.Nr. 1371-33
 pre-turned, 9mm filter Best.Nr. 1372-33

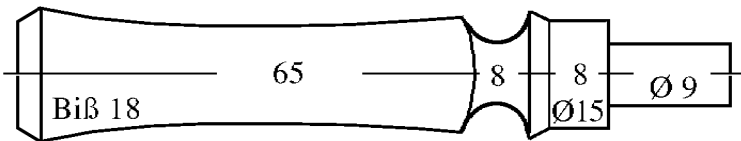

Mouthpiece Nr. 34

raw blank Best.Nr. 1370-34
 pre-turned, non-filter Best.Nr. 1371-34
 not suitable for 9mm filters

Mouthpiece Nr.35 is no longer available

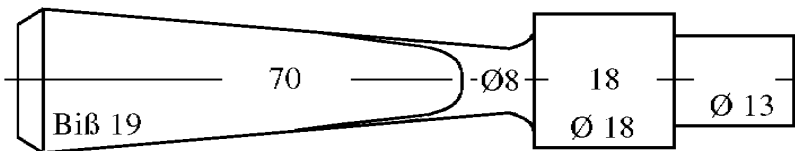

Mouthpiece Nr. 36

raw blank Best.Nr. 1370-36
 pre-turned, non-filter Best.Nr. 1371-36
 pre-turned, 9mm filter Best.Nr. 1372-36

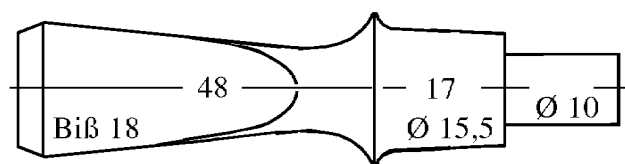

Mouthpiece Nr. 37

raw blank Best.Nr. 1370-37
 pre-turned, non-filter Best.Nr. 1371-37
 not suitable for 9mm filters

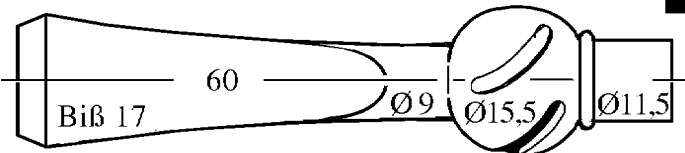

Mouthpiece Nr. 38

raw blank Best.Nr. 1370-38
 pre-turned, non-filter Best.Nr. 1371-38
 pre-turned, 9mm filter Best.Nr. 1372-38

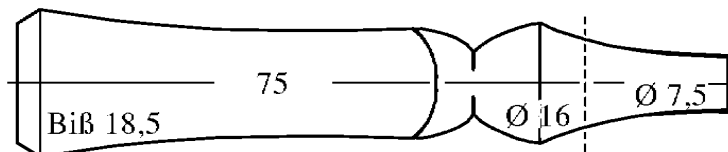

Mouthpiece Nr. 39

raw blank Best.Nr. 1370-39
 pre-turned, non-filter Best.Nr. 1371-39
 not suitable for 9mm filters

Mouthpiece Nr.40 is no longer available

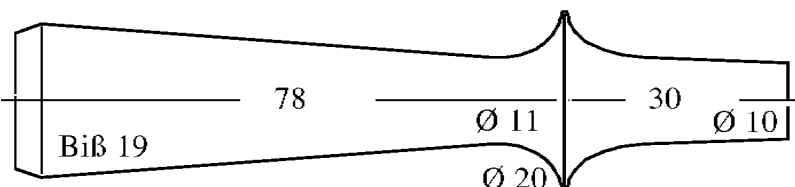

Mouthpiece Nr. 41

raw blank Best.Nr. 1370-41
 pre-turned, non-filter Best.Nr. 1371-41
 not suitable for 9mm filters

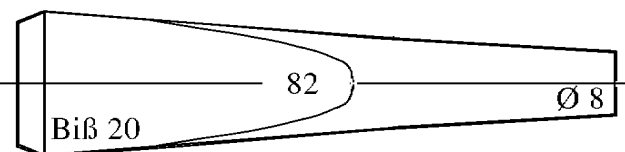

Mouthpiece Nr. 43

raw blank Best.Nr. 1370-43
 pre-turned, non-filter Best.Nr. 1371-43
 nicht für 9mm Filter geeignet
 not suitable for 9mm filters

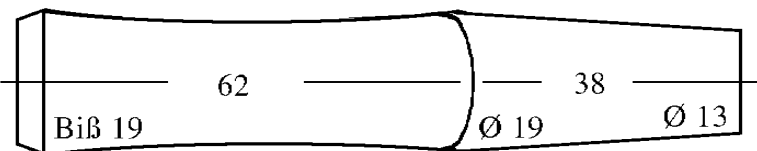

Mouthpiece Nr. 44

raw blank Best.Nr. 1370-44
 pre-turned, non-filter Best.Nr. 1371-44
 pre-turned, 9mm filter Best.Nr. 1372-44

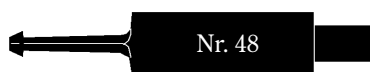

Mouthpieces Nr.45, Nr.46 and Nr.47 are no longer available.

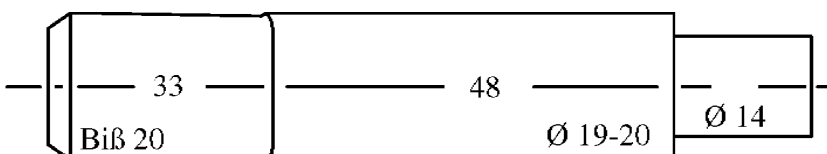

Mouthpiece Nr. 48

raw blank Best.Nr. 1370-48
 pre-turned, non-filter Best.Nr. 1371-48
 pre-turned, 9mm filter Best.Nr. 1372-48

Raw materials for handcut mouthpieces

Here we offer you two of the most popular materials from which you can freely shape your mouthpieces to your own designs:

Ebonite rod of extra high density and strength, available in **plain black** colour or in **black and red marbled colour („Cumberland“)**, and

„Cultured Amber“ amber resin sheet in **honey yellow** or in **Brandy brown** colour, a marbled transparent amber-like resin which is frequently used by artistic Danish pipemakers for both mouthpieces and mouthpiece or stem decorations. Our former supplier has given up his production and we were able to find a new supplier. Until further notice, **„Cultured Amber“ is not available.**

Ebonite rod, black, Ø appr. 22 mm

appr. 120 mm long: Best.Nr. 1373-1 **appr. 500 mm long:** Best.Nr.1373-11

Ebonite rod, black and red („Cumberland“, Ø appr. 22 mm

appr. 120 mm long: Best.Nr. 1373-2 **appr. 500 mm long:** Best.Nr.1373-21

Amber resin sheet, „Honey“, appr. 23 x 23 mm, appr. 110 mm long:

Honey coloured yellow, marbled with lighter and darker colours **not available**
Best.Nr. 1374-1

Amber resin sheet, „Brandy“, appr. 23 x 23 mm, appr. 110 mm long:

Medium brown, slightly transparent, with darker „cloudy“ grain **not available**
Best.Nr. 1374-2

How to work the mouthpiece raw materials.

The first step is to drill the smokehole with a long 2,5 mm diameter spiral drill, the square-shaped amber resin sheet should have been turned down to round shape before. If a sufficiently long drill is not available you can work from both ends of the rod. Do not drill in one single go but take care to remove drilling dust by each cm of depth. With ebonite rod, the peg can be turned directly on a lathe. The amber resin being fairly brittle requires the turning of pegs from other material, ebonite by preference. The peg is then glued into a hole of corresponding size with „Express Glue“. Take care to apply the glue generously to both peg and hole and push the peg in at once. Remainders of glue can be taken off with acetone, the smokehole should again be drilled after the glue has hardened.

Shaping is best done with medium grid files and with medium to fine grid sanding twill. Working the amber resin with a file requires much care without too much pressure to avoid splitting or flaking-off. Take care to evenly leave sufficient material as you shape the bit. We recommend not to fall below a thickness of 4 mm with ebonite rod or 5 - 5,5 mm with amber resin. The rim of the bit should not be papered down too low to achieve a comfortable fit between your teeth without having to bite too strongly with the risk of cracks. The slit in the stern can be carved out with a small (2 mm) cutter or spiral drill on a mounted hobby drill or electric motor (best do some exercise on material remainders).

If you want to bend the mouthpiece warm it evenly over the flame of a spirit lamp, a candle or the hot air from an electric hot-air paint-stripping fan to make it flexible. Make sure to permanently move and turn the mouthpiece to avoid burning the thin edges on both sides. Test its flexibility from time to time but avoid to bend too hard. Amber resin requires special care: if it gets too hot it will just tear apart (specially with very thick mouthpieces). We recommend to let it cool down superficially after the heating (can be supported by very shortly dipping it into cold water several times) and bend it slowly and very gently with a soft cloth or leather for heat protection. Then hold it in position and cool it by dipping it into cold water. *Amber resin, once bent to shape and completely cooled out, should never be heated again* - it will most certainly split and break apart due to the high tensions inside the material. Ebonite is easier to handle, it can be re-heated without problems and shaped again if not satisfied.

Acrylic

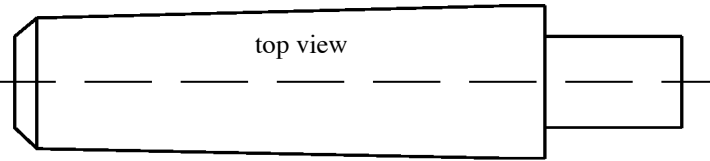

Nr. 1 A

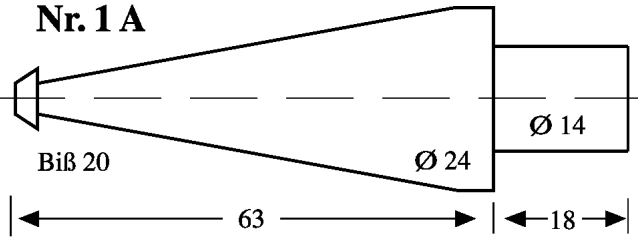

Mouthpiece Nr. 1 A
 raw blank
 pre-turned, non-filter
 pre-turned, 9mm filter

Best.Nr. 1376-1
 Best.Nr. 1377-1
 Best.Nr. 1378-1

Nr. 2 A

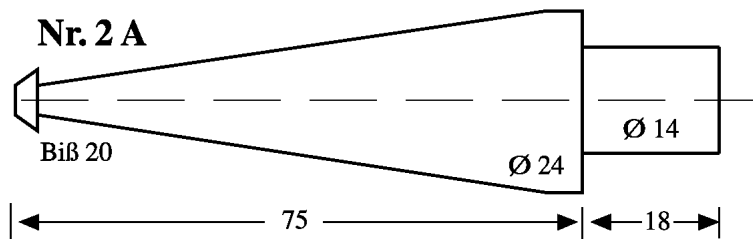

Mouthpiece Nr. 2 A
 raw blank
 pre-turned, non-filter
 pre-turned, 9mm filter

Best.Nr. 1376-2
 Best.Nr. 1377-2
 Best.Nr. 1378-2

Nr. 3 A

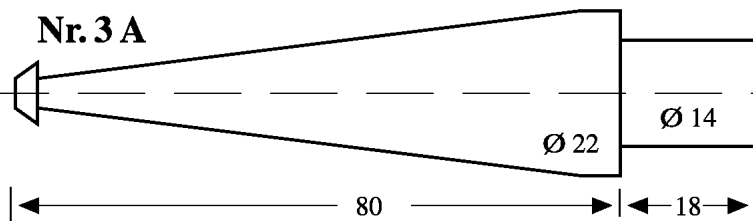

Mouthpiece Nr. 3 A
 raw blank
 pre-turned, non-filter
 pre-turned, 9mm filter

Best.Nr. 1376-3
 Best.Nr. 1377-3
 Best.Nr. 1378-3

Nr. 4 A

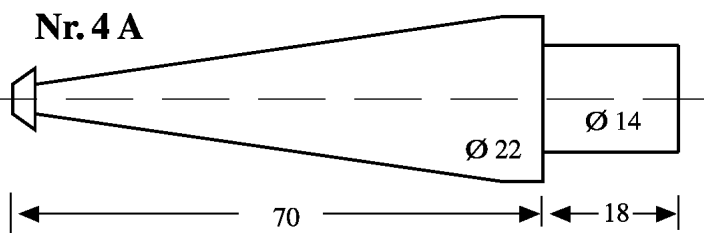

Mouthpiece Nr. 4 A
 raw blank
 pre-turned, non-filter
 pre-turned, 9mm filter

Best.Nr. 1376-4
 Best.Nr. 1377-4
 Best.Nr. 1378-4

Nr. 5 A

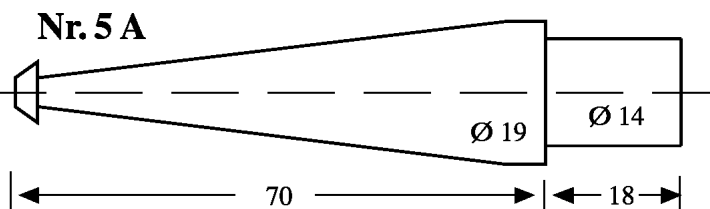

Mouthpiece Nr. 5 A
 raw blank
 pre-turned, non-filter
 pre-turned, 9mm filter

Best.Nr. 1376-5
 Best.Nr. 1377-5
 Best.Nr. 1378-5

Nr. 6 A

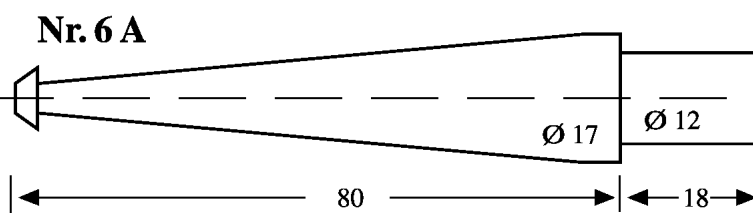

Mouthpiece Nr. 6 A
 raw blank
 pre-turned, non-filter
 pre-turned, 9mm filter

Best.Nr. 1376-6
 Best.Nr. 1377-6
 Best.Nr. 1378-6

Acrylic

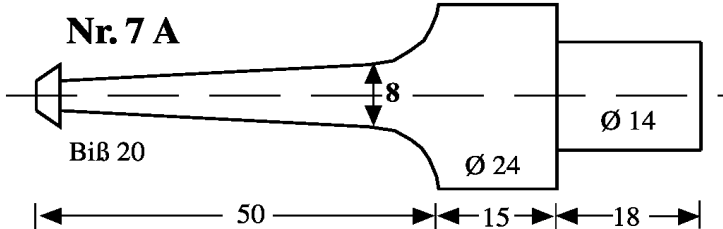
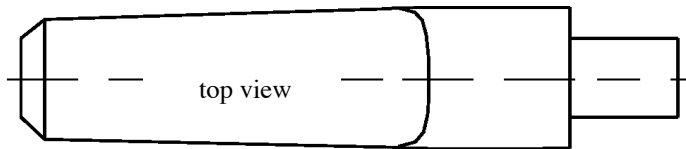

Mouthpiece Nr. 7 A
raw blank
pre-turned, non-filter
pre-turned, 9mm filter

Best.Nr. 1376-7
Best.Nr. 1377-7
Best.Nr. 1378-7

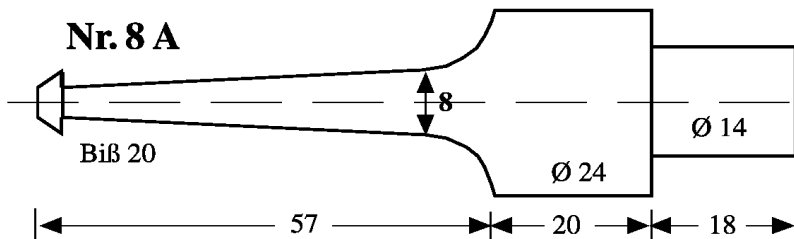

Mouthpiece Nr. 8 A
raw blank
pre-turned, non-filter
pre-turned, 9mm filter

Best.Nr. 1376-8
Best.Nr. 1377-8
Best.Nr. 1378-8

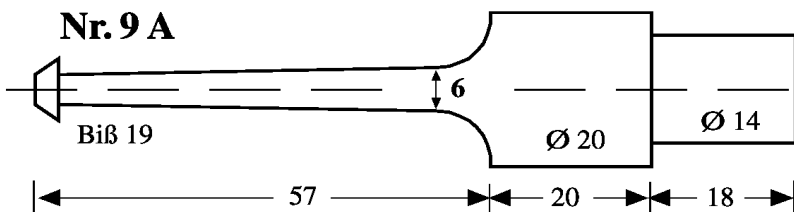

Mouthpiece Nr. 9 A
raw blank
pre-turned, non-filter
pre-turned, 9mm filter

Best.Nr. 1376-9
Best.Nr. 1377-9
Best.Nr. 1378-9

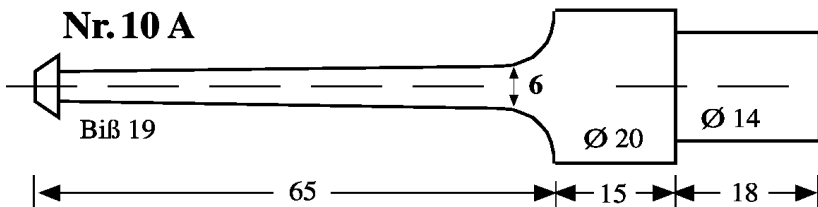

Mouthpiece Nr. 10 A
raw blank
pre-turned, non-filter
pre-turned, 9mm filter

Best.Nr. 1376-10
Best.Nr. 1377-10
Best.Nr. 1378-10

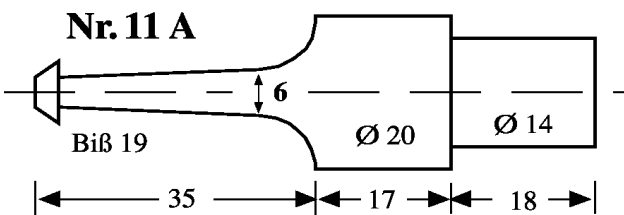

Mouthpiece Nr. 11 A
raw blank
pre-turned, non-filter
pre-turned, 9mm filter

Best.Nr. 1376-11
Best.Nr. 1377-11
Best.Nr. 1378-11

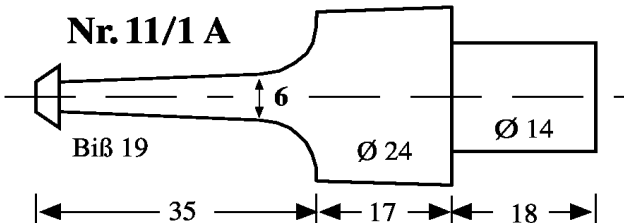

Mouthpiece Nr. 11/1 A
raw blank
pre-turned, non-filter
pre-turned, 9mm filter

Best.Nr. 1376-111
Best.Nr. 1377-111
Best.Nr. 1378-111

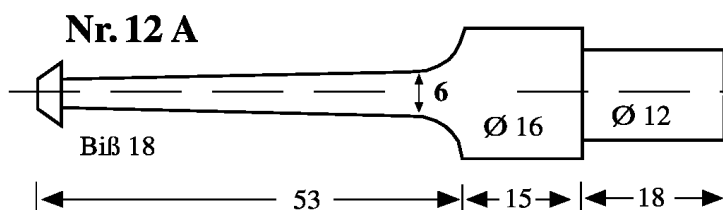

Mouthpiece Nr. 12 A
raw blank
pre-turned, non-filter
pre-turned, 9mm filter

Best.Nr. 1376-12
Best.Nr. 1377-12
Best.Nr. 1378-12

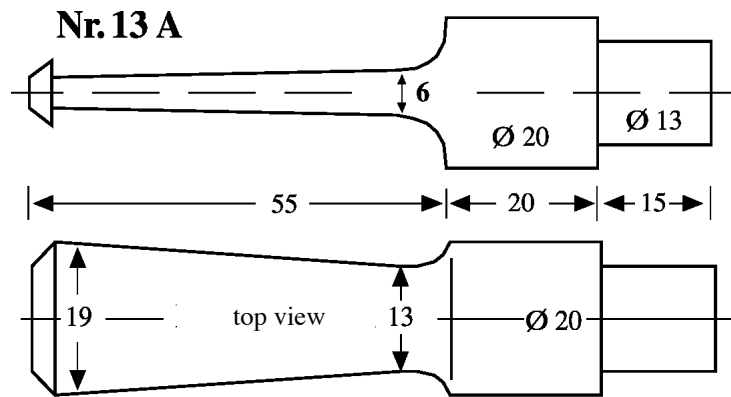

Mouthpiece Nr. 13 A

raw blank Best.Nr. 1376-13
 pre-turned, non-filter Best.Nr. 1377-13
 pre-turned, 9mm filter Best.Nr. 1378-13

Acrylic

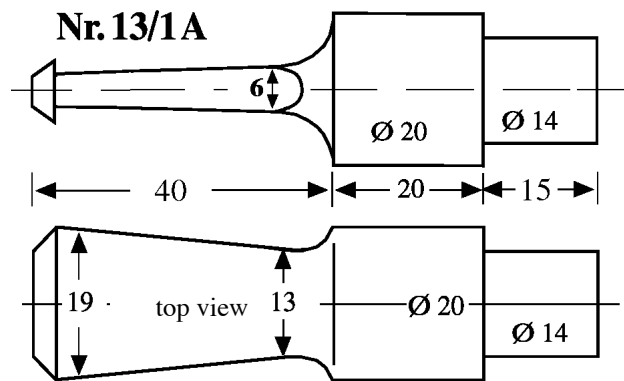

Mouthpiece Nr. 13/1 A

raw blank Best.Nr. 1376-131
 pre-turned, non-filter Best.Nr. 1377-131
 pre-turned, 9mm filter Best.Nr. 1378-131

Mouthpiece Nr. 23 A is no longer available

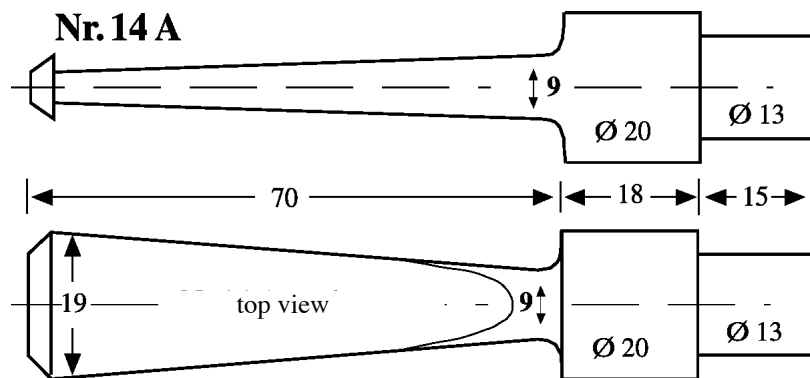

Mouthpiece Nr. 14 A

raw blank Best.Nr. 1376-14
 pre-turned, non-filter Best.Nr. 1377-14
 pre-turned, 9mm filter Best.Nr. 1378-14

Acrylic mouthpieces, oval, saddle, black

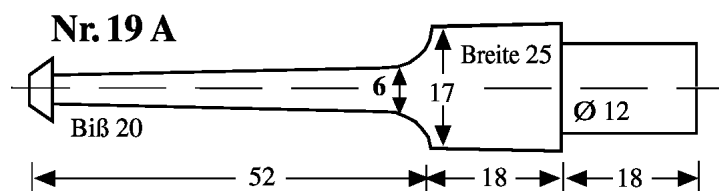

Mouthpiece Nr. 19 A

raw blank Best.Nr. 1376-19
 pre-turned, non-filter Best.Nr. 1377-19
 pre-turned, 9mm filter Best.Nr. 1378-19

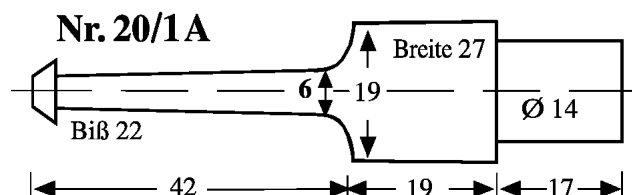

Mouthpiece Nr. 20/1 A

raw blank Best.Nr. 1376-20
 pre-turned, non-filter Best.Nr. 1377-20
 pre-turned, 9mm filter Best.Nr. 1378-20

Acrylic mouthpieces, oval, tapered, black

(Please read our explanations on page 8!)

Nr. 21 A

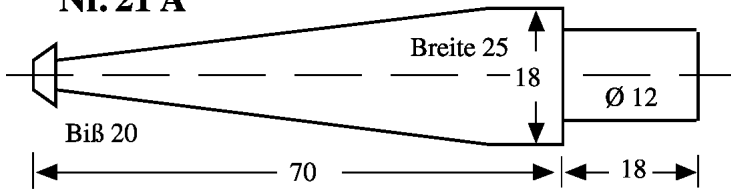

Mouthpiece Nr. 21 A

raw blank Best.Nr. 1376-21
pre-turned, non-filter Best.Nr. 1377-21
pre-turned, 9mm filter Best.Nr. 1378-21

Nr. 22 A

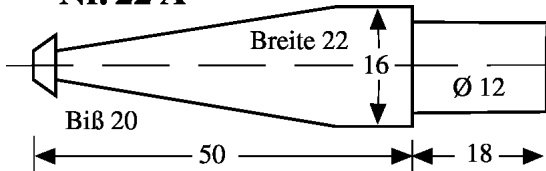

Mouthpiece Nr. 22 A

raw blank Best.Nr. 1376-22
pre-turned, non-filter Best.Nr. 1377-22
pre-turned, 9mm filter Best.Nr. 1378-22

Acrylic

Acrylic mouthpieces, square-cut, saddle, black

Nr. 15 A

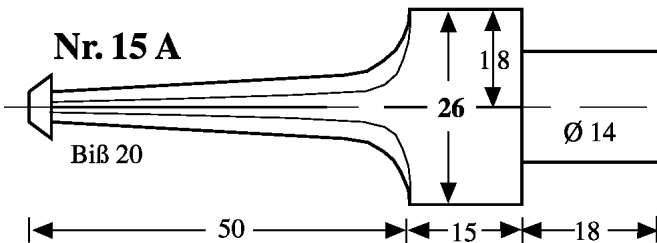

Mouthpiece Nr. 15 A

raw blank Best.Nr. 1376-15
pre-turned, non-filter Best.Nr. 1377-15
pre-turned, 9mm filter Best.Nr. 1378-15

Nr. 16 A

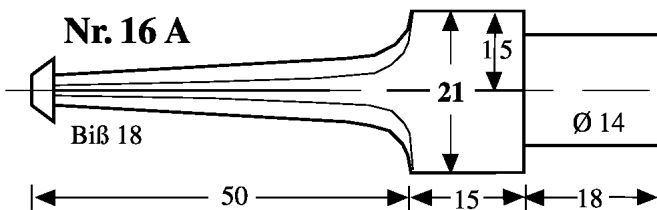

Mouthpiece Nr. 16 A

raw blank Best.Nr. 1376-16
pre-turned, non-filter Best.Nr. 1377-16
pre-turned, 9mm filter Best.Nr. 1378-16

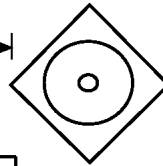

Acrylic mouthpieces, square-cut, tapered, black

Nr. 17 A

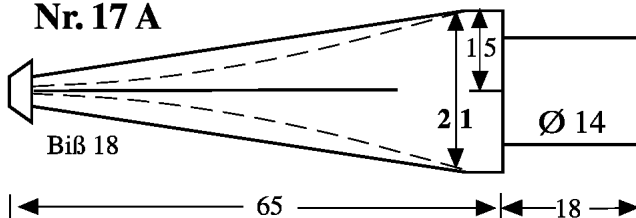

Mouthpiece Nr. 17 A

raw blank Best.Nr. 1376-17
pre-turned, non-filter Best.Nr. 1377-17
pre-turned, 9mm filter Best.Nr. 1378-17

Nr. 18 A

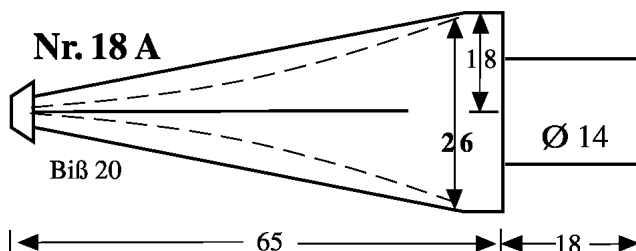

Mouthpiece Nr. 18 A

raw blank Best.Nr. 1376-18
pre-turned, non-filter Best.Nr. 1377-18
pre-turned, 9mm filter Best.Nr. 1378-18

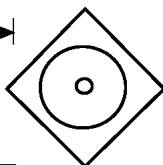

We have been using these mouthpieces in our repair workshop for quite a while, they are available as „Honey“ (yellow, slightly marbled) and „Brandy“ (brown marbled, transparent). Even if they do not look quite as natural as the amber resin (p.14), they certainly are a robust and good value alternative.

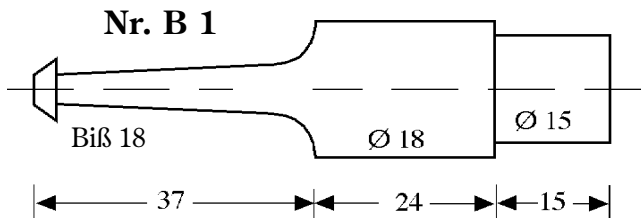

Nr. B 1

Mouthpiece Nr. B 1 Honey

raw blank Best.Nr. 1376-B 10
 pre-turned, non-filter Best.Nr. 1377-B 10
 pre-turned, 9mm filter Best.Nr. 1378-B 10

top view of
 Nr. B 1 + Nr. B 2

Acrylic

Mouthpiece Nr. B 1 Brandy

raw blank Best.Nr. 1376-B 11
 pre-turned, non-filter Best.Nr. 1377-B 11
 pre-turned, 9mm filter Best.Nr. 1378-B 11

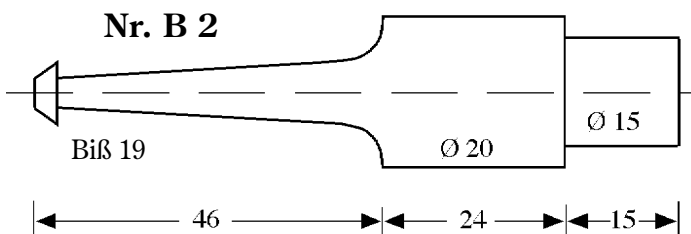

Nr. B 2

Mouthpiece Nr. B 2 Honey

raw blank Best.Nr. 1376-B 20
 pre-turned, non-filter Best.Nr. 1377-B 20
 pre-turned, 9mm filter Best.Nr. 1378-B 20

Mouthpiece Nr. B 2 Brandy

raw blank Best.Nr. 1376-B 21
 pre-turned, non-filter Best.Nr. 1377-B 21
 pre-turned, 9mm filter Best.Nr. 1378-B 21

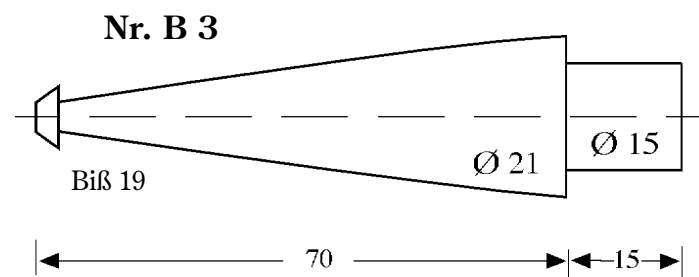

Nr. B 3

Mouthpiece Nr. B 3 Honey

raw blank Best.Nr. 1376-B 30
 pre-turned, non-filter Best.Nr. 1377-B 30
 pre-turned, 9mm filter Best.Nr. 1378-B 30

Mouthpiece Nr. B 3 Brandy

raw blank Best.Nr. 1376-B 31
 pre-turned, non-filter Best.Nr. 1377-B 31
 pre-turned, 9mm filter Best.Nr. 1378-B 31

top view of
 Nr. B 3 + Nr. B 4

Mouthpiece Nr. B 4 Honey

raw blank Best.Nr. 1376-B 40
 pre-turned, non-filter Best.Nr. 1377-B 40
 pre-turned, 9mm filter Best.Nr. 1378-B 40

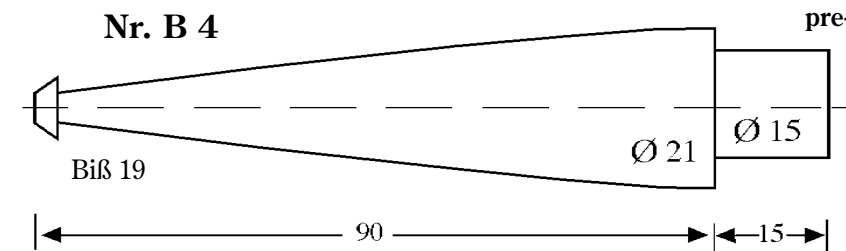

Nr. B 4

Mouthpiece Nr. B 4 Brandy

raw blank Best.Nr. 1376-B 41
 pre-turned, non-filter Best.Nr. 1377-B 41
 pre-turned, 9mm filter Best.Nr. 1378-B 41

Solid horn tips for decorations

Individually handmade artistic pipes are often decorated with various materials. Being a natural material the same as briarwood, it is most obviously suitable as an additional decorative eye-catcher when combined with vividly grained briar and will add „that certain touch“ to many a pipe. But also for more practical reasons the use of horn may be appropriate: should flaws or cracks in the stem come to light when shaping the pipe, the only way of getting rid of the flaws is to cut the stem down to shorter length. It can then be attractively made longer again by attaching a piece of horn.

Horn tips,

Best.Nr. 1375-1

solid cattle horn tips of mixed colour, appr. 8 - 12 cm long and 3 - 4 cm thick

The simplest way of connecting horn parts to the pipe stem is to turn the horn tip to exactly round shape and then turn a peg that fits into the hole in the stem. Both parts are then glued together with a waterresistant wood glue (or „Express Glue“). For better stability you can also drill a thread into the stem and cut a corresponding thread on the horn peg (thread size 10 mm for non-filter pipes, 12 mm for filter pipes). Parts are then glued together. If the stem is too thin (14mm and below) you can use a metal tube (aluminium or stainless steel) with outside thread of 6mm diameter. If not available you can use a screw with 6mm thread, cut off the head and drill through lengthways to 3,5 mm. Drill a 6mm thread into both stem and horn to take the connecting thread. Put on glue generously and screw both parts together tightly. Connecting horn parts to bent pipes will in most cases require additional carving of the smokehole in the stem to achieve and maintain a good draught and to be able to insert pipe cleaners down into the bowl after the horn is fixed. This can be done with a 3,5mm spiral drill, it does though require some experience and a steady hand. The spinning drill is carefully moved down into the smokehole and slowly pulled back again slightly tilted to widen the smokehole in several steps.

Special colour stains for briarwood

For the colouring of pipe bowls we offer you a choice of 11 different colour stains from Denmark as they are used by pipemakers and in pipe factories. Their special alcohol-based composition makes them sink into the wood deeply and fast for brilliant and lasting colours. These stains are available as a set of 11 colours (with the most used colour black 2 x), each one of them can also be ordered singly.

Special colour stains, set of 12 bottles

(12 x 60 ml)

Best.Nr.1387-25

„Orange“ is no longer available - the set of 12 now contains 2 bottles of the contrast stain „Schwarz“.

The following colours are part of the set and can also be ordered singly in bottles of 60 ml:

Nr.1387-11: Gelb (yellow)

Nr.1387-12: Orange, no longer available

Nr. 1387-13: Ocker (light brown)

Nr.1387-14: Hellrot (light red)

Nr.1387-15: Rot extra (full red)

Nr.1387-16: Mahagoni hell (light mahogany)

Nr.1387-17: Mahagoni dkl. (dark mahogany)

Nr.1387-18: Nußbraun (walnut)

Nr.1387-19: Tiefbraun (dark brown)

Nr. 1387-20: Grün (green)

Nr. 1387-21: Blau (blue)

Nr. 1387-22: Schwarz (black)

Our special colour stains have proven to be most suitable for attractive colouring of briar pipe bowls. If the bowl is free of flaws (it is said to have happened...) you can try „Rot extra“ as basic contrast stain and then do the second colouring with „Gold“ oder „Ocker“ to create a brilliant and vivid appearance. If the grain is less vivid or the briar more or less speckled with flaws, you can still get attractive results by using „Mahagoni“, „Rot extra“ or „Nußbraun“ (can also be applied one after the other or as a blend) on a black basic stain. Our instructions leaflet gives you more detailed information (see page 23).

Protective sealings for pipe bowls

To protect the briar after the final smooth papering and, above all, after the colouring, and also to intensify the briar's grain, the wood has to be treated with some kind of sealing. Our instructions leaflet will tell you how to proceed (see page 23). A choice of various materials is presented here.

Linseed oil varnish, bottle of 50 ml

Best.Nr. 1385-1

Linseed oil varnish is a highly approved natural sealing agent that has been used for protection and also undercoating of all sorts of raw wood for many centuries. It contains a resin that oxidizes and hardens in the air without considerably blocking the wood's breathing abilities and is therefore also most suitable for the sealing of briar pipes for which a matted finish is desired. This varnish will bind the dye soaked into the wood and prevent the colour to be rubbed off when the pipe is smoked. It can also serve as undercoating for a following wax polished finish. The linseed oil varnish is generously put on the briar bowl, left to soak in for about 1 hour and then wiped off again. The bowl must then rest for 1 - 2 weeks to let the varnish harden, for a subsequent wax polish 2 weeks at minimum.

Bee's wax, natural colour, bag of appr. 80 g

Best.Nr. 1385-2

Bee's wax is another alternative for a natural wood conservation and sealing and it may have the longest tradition of all wood sealing agents. It is still known and popular today as ingredient of many furniture polishing wax compositions specially for the care of antique polished furniture.

For the use on pipes it is melted and applied liquidly to the pre-heated (and intermediately re-heated) wood to make it optimally soak in (please, find more information in our instructions leaflet of page 23). Bee's wax will intensify the briar's grain and create a matted finish to the pipe bowl which can be refreshed from time to time, and it leaves the wood's pores open for unimpeded breathing. As it is fairly soft, it is not suitable as undercoating for a wax polished finish.

Of course, you can use other undercoatings or wood sealings that can be found in Do-It-Yourself markets or paint shops, e. g. nitro-cellulose-based varnishes. anderer Schleif- und Einlaßgrund z.B. auf Nitrobasis, wie ihn Bau- und Heimwerkermärkte anbieten. All those who want to avoid the vapours from the solvents of those petro-chemical products can fall back on a third traditional natural sealing and coating substance:

Shellack polish in flakes, bag of appr. 50g

Best.Nr. 1385-3

As ready-made shellack polish was only rarely available in Do-It-Yourself markets we have switched over to prepare it ourselves for the use in our workshop. The shellack comes in thin flakes. To prepare the liquid polish, you add 1 part shellack flakes to 4 -6 parts pure spirit (ethanol 96%) or isopropanol alcohol (both available from chemists) in some appropriate glass and gently warm the liquid with the glass heated in boiling water (bain-marie from the kitchen) permanently stirring until the flakes have dissolved completely. *Denatured spirit* can also be used, but *be sure it has a neutral smell*. Otherwise the denaturing additives will soak into the wood, and their ugly smell and taste being really penetrant and persistent, you might never find pleasure in smoking this pipe. The amber-coloured clear shellack solution can be diluted with pure alcohol if necessary and it serves really well for the preparation of the bowl for a subsequent wax polished finish. It dries fairly quickly and does not require too much time of waiting. Its ability to dissolve and slightly brighten the colour of the wood stains can be compensated by a more intensive colouring. This can be achieved by repeatedly burning off the stain surplus on the bowl over a flame right after it was put on and only wiping off the surplus after the last layer of stain (this method is used in some pipe factories). Please, take care to put aside all flammable substances before you start this procedure which, by the way, will not do any harm to the briar.

Sanding and polishing materials for pipe bowls and mouthpieces

For shaping and stepwise smoothing out pipe bowls and mouthpieces we offer a **sanding twill** specially designed to work all sorts of wood. It comes in strips of 4 cm width and 100cm length. Its textile base makes it much more flexible and lasting than customary sanding papers which is a great advantage when working rounded shapes.

Sanding twill, 3 strips 4 cm x 100 cm, 1 each grid 100, 180, 400

Best.Nr. 1382-2

Grid 100 is used for shaping and for levelling uneven areas and grooves after the use of rasp and file, grid 180 is used to further smooth out the surface of bowl, stem and mouthpiece, grid 400 finally is used to paper the rest of scratches out and to create a really smooth surface. It can also be used to paper down the surplus after having put on the first colour stain for a contrast colouring. zum endgültigen Feinschleifen und Glätten sowie auch zum oberflächlichen Abtragen der dunklen Kontrastbeize. To work mouthpieces, grid 180 and 400 should normally be sufficient and achieve good results.

Polishing of mouthpieces and pipe bowls can almost professionally be done with our specially composed **DAN PIPE Polishing Set**. It contains two 150 mm cloth polishing reels, a carrier shaft for changing the reels, two different grades of polishing wax and a detailed instructions leaflet.

Our Polishing Set was designed for the use with a customary electric hobby drill mounted on a table or work-bench in a swivel holder (available in Do-It-Yourself markets if not at hand). The machine is fixed horizontally with the cloth reel spinning towards your body. The cloth reels are screwed to the carrier shaft and clamped in the drilling chuck. To achieve good results, you should have one reel for only one type of wax. Never be sparing with wax - it is the wax that does the polishing, not the cloth reel. All further information on the use of this Polishing Set is described in the instructions leaflet.

DAN PIPE Polishing Set, complete equipment (see above)

Best.Nr. 6507-1

components available singly:

Cloth polishing reel, Ø 150 mm

Best.Nr. 6507-2

Special carrier shaft

Best.Nr. 6507-3

Pre-polishing wax, brown, appr. 220g

Best.Nr. 1380-1

High shine wax, cream colour, appr. 220g

Best.Nr. 1380-2

In addition to the Polishing Set we offer a special natural wax for a coating wax polished finish: **Carnauba wax**, an extremely hard wax from the leaves of the Polynesian Carnauba Palm.

Carnauba wax, unbleached, appr. 50 - 60g (very rich and lasting)

Best.Nr. 1380-3

Wooden grab handle

Best.Nr. 1382-3

This grab handle was specially designed for the use with our hobby blocks. Its square end can be fixed in a vice or with clamps to a table or work-bench, the round tapered end is meant to be stuck firmly into the tobacco hole. You can then freely shape the pipe bowl with rasp, file or sanding twill using both hands, you change the pipe's position from time to time to reach and work it evenly from all sides including the bottom part. The diameter of tobacco holes in our hobby blocks may vary. Should the conic end of the grab handle therefor not fit tightly in, you can either shorten the tapered end of the handle or wrap some adhesive tape or stiff paper around it to increase its width.

Tobacco holes coated with a black „break-in aid” are standard today in most all customary briar pipes. This coating is supposed to protect the briar from the tobacco’s burning heat during the break-in period and prevent it from burning in. We have developed this paste and have been using it in our own pipe workshop with best results for nearly twenty years. It is blended from two components into a creamy liquid that is put onto the clean walls inside the tobacco hole. It will dry and harden within one or two hours time, and the pipe can then be filled and smoked. It can, of course, also be used for repairs of less severe burns in pipes already used. Detailed instructions come with every pack.

Information material about hobby pipemaking

The main work when making a pipe is done with rasp, files and sanding paper or twill, and the tools present in most households should do and only slightly have to be completed. What should, of course, not miss is a good portion of patience, skill and, above all, joy in creative artistic working. All materials necessary can be found in this our Hobby Catalogue. To help you with your work we highly recommend our **Hobby Instructions** - specially to all those who want to make their first try in being a pipemaker. And you can also watch the creation of a pipe made from one of our hobby blocks „live“ in our **video film „Pfeifen selbst gemacht“** („Carve Your Own Pipe“ - available in German only).

Hobby Instructions (English version)Best.Nr. 1340-7 E

This little leaflet describes and explains the main steps on the way from the hobby block to the finished pipe. Highly recommended to all those who have never before tried to make their own pipe. It is meant to help you avoid making too many sometimes severe mistakes that might discourage you and make you give up before you have seen a final result. We want you to find pleasure in and have fun with this creative hobby, and that your pleasure may last, which can only come true if all your efforts are crowned by success in the end.

Video film „Pfeifen selbst gemacht”, VHS, appr. 45 min.Best.Nr. 1340-1

In this little video Holger Frickert detailedly and vividly demonstrates and describes how you can carve your own pipe at home with our hobby articles. You can watch the growing of a briar pipe from the first sketch, the preparation of the briar block, the many steps of working the wood (shaping, carving, papering etc.) and working the mouthpiece to colouring and finishing the pipe. And as you watch, the one or the other little tip of importance seen here can make your own work easier.

This video is only available in German language, but as it is based on and accompanied by our translated instructions leaflet (see above), so it should still be possible to follow the film action (many people find it easier to learn by watching and repeating than by only following spoken or written instructions...).

We are well aware that our Hobby Catalogue can only show and contain an extract from the large palette of materials that are used in pipemaking. But we are convinced to have displayed all that is important and necessary for your work as a **hobby pipemaker**. Our intention is not to become a supplier to professional pipemakers (who have their own resources anyway, and most artists prefer to keep them secret). Should you, in the course of working on your own pipes, find that you cannot get any further or look for materials not included in our assortment, do not hesitate to ask us for help and advice. We will gladly provide you with hints and information to help you get along.

Pipe Classics - Shape Chart

